

Dane zamawiającego:

Data:

Sugerowana data dostawy:

## 01. WARUNKI ZABUDOWY

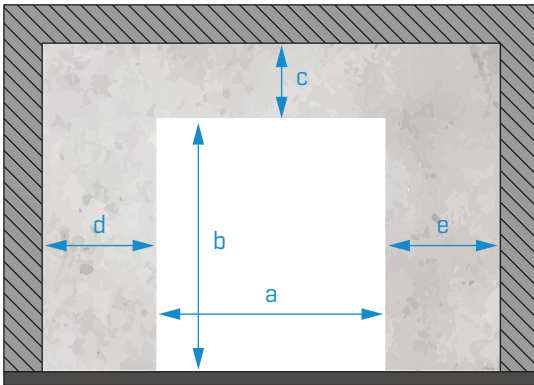

Ilość

Wymiary w [mm]:

**POŁA  
OBOWIĄZKOWE**

a

b

c

d

e

Kolor kurtyny PVC:



Inne:

Opcje dodatkowe sterowania

Model

Radar

Pilot

Montaż tunelowy

Inne

Inne

Wyłącznik pociągowy

Model

Kolor standardowy RAL9010

[wykończenie strukturalne]

Inny kolor konstrukcji:

INOX 304

INOX 316

Uwagi:

Miejsce na uwagi produkcyjne:

POŁOŻENIE SIŁOWNIKA I CENTRALI STERUJĄCEJ:

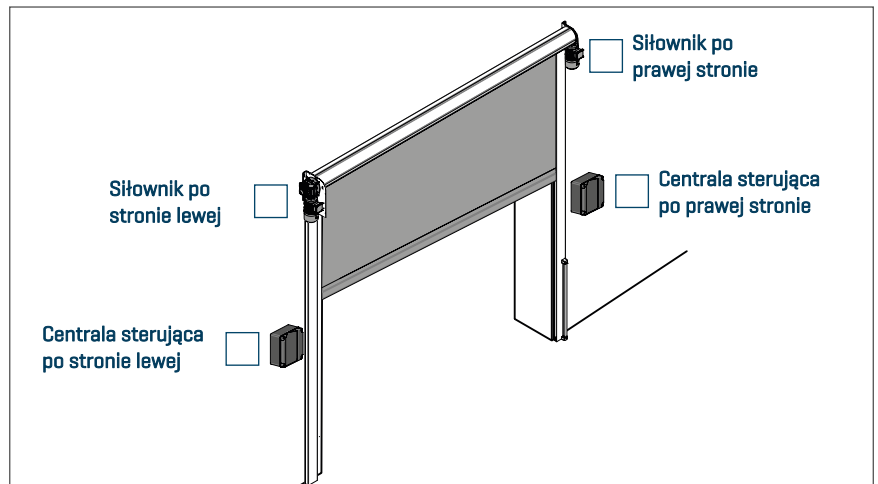

MIEJSCE NA RYSUNKI PRODUKCYJNE:

## 02. RYSUNEK TECHNICZNY - MONTAŻ Z SIŁOWNIKIEM BOCZNYM [LEWY LUB PRAWY]

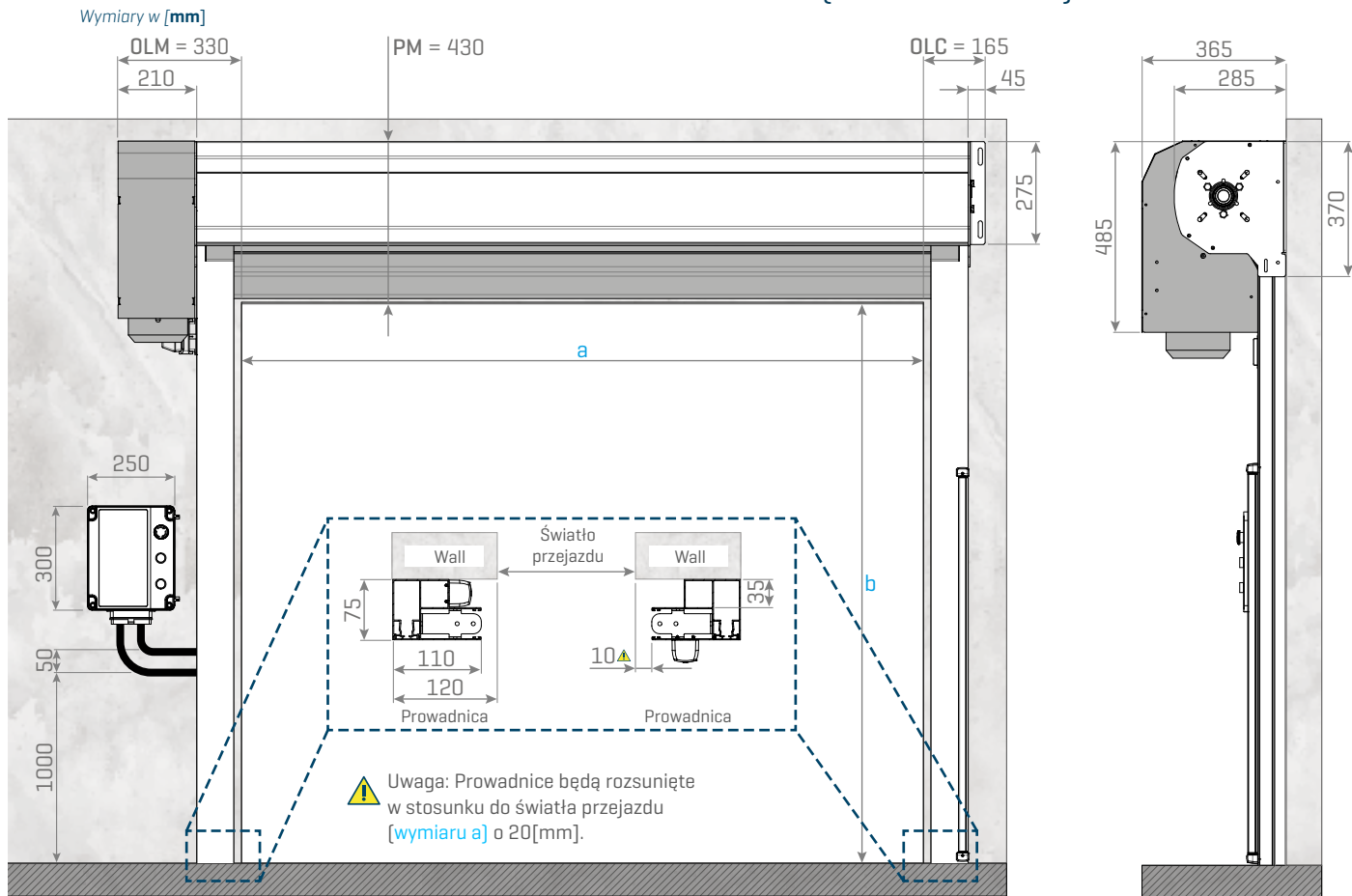

## 03. RYSUNEK TECHNICZNY - MONTAŻ TUNELOWY Z SIŁOWNIKIEM BOCZNY [LEWY LUB PRAWY]

